

Serie F.100



RESILIENT SEATED GATE VALVE

F.100



The valve model F.100 is resilient seated gate valve, made of ductile iron, manufactured in accordance with severe product norms and relevant norms, and in conformity to EN ISO 9001

These valves are suitable for heating and conditioning (HVAC), water treatment and water distribution, waste water, industrial applications, agricultural purposes.

NO: for steam, for choking and regulation of the flow

Application fields



WATER



CONDITIONING



INDUSTRY



DRINKING WATER



FIRE FIGHTING



www.flowsureglobal.com.tr

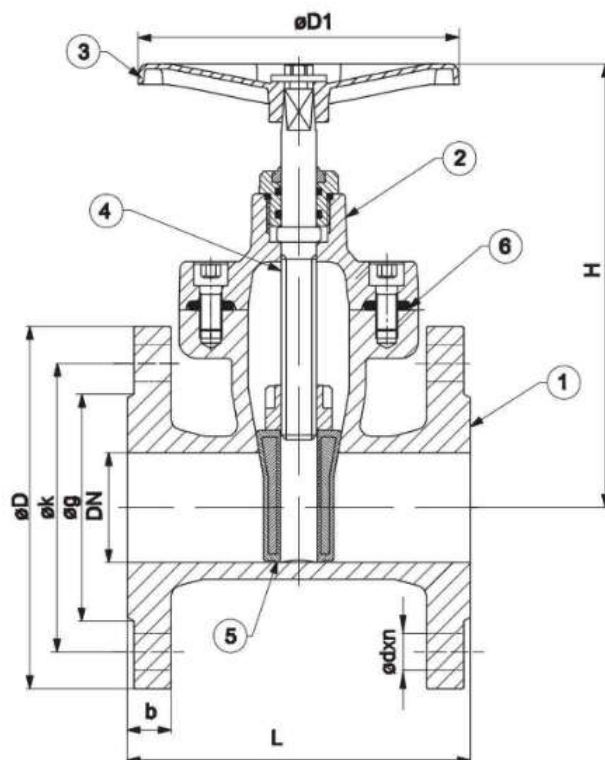

Materials

Component	Material
1 Body	GGG 50 - EN GJS 500-15 - Ductile Iron
2 Bonnet	GGG 50 - EN GJS 500-15 - Ductile Iron
3 Handwheel	GGG 50 - EN GJS 500-15 - Ductile Iron
4 Stem	X20Cr13 - AISI420 - Stainless steel
5 Wedge	GGG 50 - EN GJS 500-15 - Ductile Iron + Rubber Coated
6 Gasket	EPDM - NBR

Dimensions (mm)

DN	40	50	65	80	100	125	150	200	250	300	350	400	500	600
L	140	150	170	180	190	200	210	230	250	270	290	310	350	390
H	191	214	237	265	311	348	385	488	600	680	810	890	1234	1260
D1	160	160	160	160	200	250	250	315	315	315	400	400	500	500
D	150	165	185	200	220	250	285	340	405	460	520	580	715	840
k	110	125	145	160	180	210	240	295	355	410	470	525	650	770
b	19	19	19	19	19	19	19	20	22	24	26	28	32	36
dxn	19x4	19x4	19x4	19x8	19x8	19x8	23x8	23x12	28x12	28x12	31x16	31x16	34x20	37x20

Weight (kg)

	7.2	8.1	11.5	13.3	18.3	21.5	29.2	47.6	76.6	105.6	165.4	200	370.5	628.8
--	-----	-----	------	------	------	------	------	------	------	-------	-------	-----	-------	-------

Certificates



Standards

Design : TS EN 1171
 Flange Dimensions : TS EN1092-2 (PN 16)
 Face to Face Dimensions : TS EN 558 (Seri 14)
 Tests : TS EN 12266-1
 Nominal Pressure: PN16 (Option: PN25)
 Temperature: -10 ~ 110°C

Accessories

- Square cap for water main system connection
- Stem extension

Head loss Fluid: water (1m H₂O = 0.098bar)

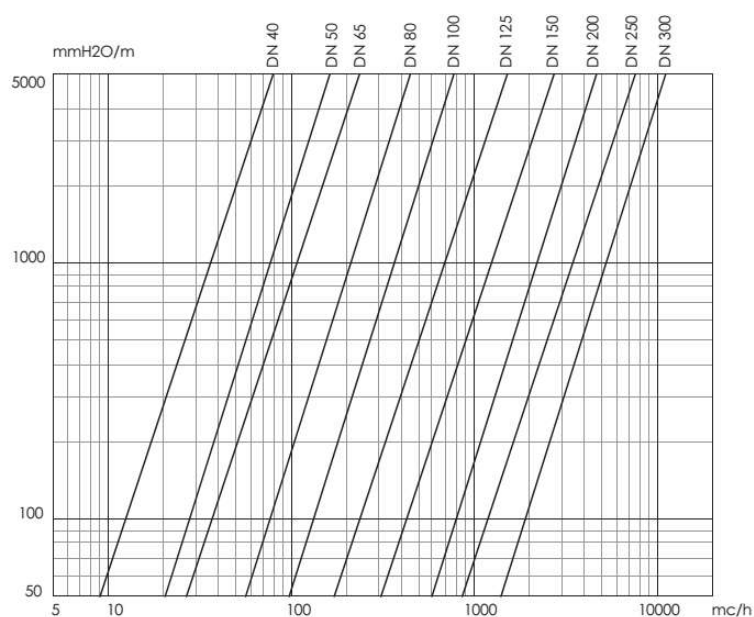

Instruction and Recommendations

STORING

Keep in dry and closed place.

RECOMMENDATIONS

Before carrying out maintenance or dismantling the valve:

Ensure that the pipes, valves and fluids have cooled down, that the pressure has decreased, and that the lines and pipes have been drained in case of toxic, corrosive, inflammable or caustic liquids. Temperatures above 50°C and below 0°C might cause damage to people.

INSTALLATION

- Handle with care
- The valve must be installed in an open or closed position.
- The lifting of the valve must be done using belts and safety hooks (fig)
- Do not weld the flanges to the piping after installing the valve
- Prior to installing the valve, ensure that the piping has been carefully cleaned and is free of any residual particles, such as soil, small stones, etc
- In case of installation in wells, ensure there is suitable drainage.
- In case of installation of valves of diameter greater than DN 200, it is recommended that a dismantling joint be installed, in order to facilitate the installation/disassembly.
- Place the valve between the flanges of the tube and put liners between the flanges of the valve and the flanges of the tube. Check that the liners are positioned correctly
- The distance between the counter flanges must be the same as the face to face distance of the valve.
- Do not use the bolts of the counter flanges to close the piping. The bolts must be tightened crosswise
- Water hammers might cause damage and ruptures. Inclination, twisting and misalignments of the piping may subject the valve to stress, once it has been installed. It is recommended that elastic joints be used, in order to reduce these effects as much as possible.

