

# Serie F.100



## BRONZE GATE VALVE

F.130



The valve model F.130 is threaded gate valve, made of bronze, manufactured in accordance with severe product norms and relevant norms, and in conformity to EN ISO 9001

These valves are suitable for heating and conditioning (HVAC), water distribution, waste water, industrial applications, agricultural purposes.

**NO:** for steam, for choking and regulation of the flow

### Application fields



WATER



CONDITIONING



INDUSTRY



DRINKING WATER



FIRE FIGHTING



[www.flowsureglobal.com.tr](http://www.flowsureglobal.com.tr)

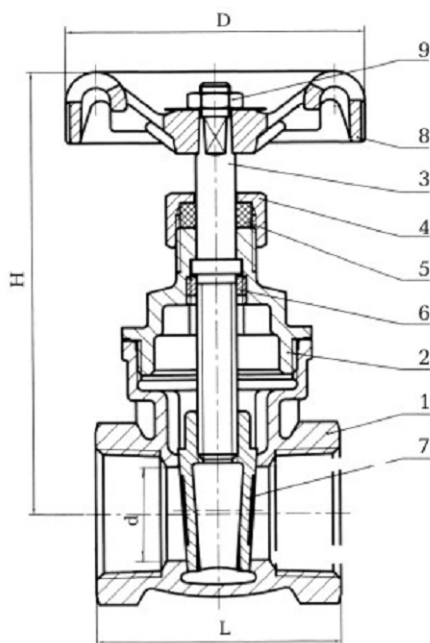

Component	Material
1 Body	CC491K - Bronze
2 Bonnet	CC491K - Bronze
3 Stem	CW602N – DZR Brass
4 Packing Nut	CW614N - Brass
5 Packing	PTFE
6 Stem Bush	CW602N – DZR Brass
7 Disc	CC491K - Bronze
8 Handwheel	Aluminum
9 Handwheel Nut	CW614N - Brass

**Dimensions (mm)**

DN	15	20	25	32	40	50
d	13	19	25	32	38	50
L	43	49	54	62	65	75
H	78	92	103	116	133	156
D	52	60	60	70	78	92

**Weight (kg)**

	0.255	0.355	0.524	0.77	1.07	1.62
--	-------	-------	-------	------	------	------

**Certificates**



**Standards**

Design : BS EN 5154  
 Thread Standard : EN ISO 7  
 Tests : TS EN 12266-1  
 Nominal Pressure: PN20  
 Temperature: -10 ~ 170°C

## Instruction and Recommendations

### **STORING**

Keep in dry and closed place.

### **RECOMMENDATIONS**

Before carrying out maintenance or dismantling the valve:

Ensure that the pipes, valves and fluids have cooled down, that the pressure has decreased, and that the lines and pipes have been drained in case of toxic, corrosive, inflammable or caustic liquids. Temperatures above 50°C and below 0°C might cause damage to people.

### **INSTALLATION**

- Handle with care
- The valve must be installed in an open or closed position.
- Do not weld the flanges to the piping after installing the valve
- Prior to installing the valve, ensure that the piping has been carefully cleaned and is free of any residual particles, such as soil, small stones, etc
- In case of installation in wells, ensure there is suitable drainage.
- Water hammers might cause damage and ruptures. Inclination, twisting and misalignments of the piping may subject the valve to stress, once it has been installed. It is recommended that elastic joints be used, in order to reduce these effects as much as possible.
- It is not recommended to install gate valve at the end of pipe. Because impurity will accumulate at the disc, which will leading leaking