

Serie F.1100

PRESSURE INDEPENDENT BALANCING CONTROL VALVE – FLANGED TYPE

F.1100



The valves in the series F.1100 balance the flow in main circuits or single sections of heating or conditioning plants, such as PAU, AHU, MAU and end-equipment.

They allow correcting irregularities in the supply of the single users (irregularities which might cause noise and damage the components of the plant) and, as a result, improve environmental comfort and optimize energy consumption.

Equal percentage flow characteristic.

Constant differential pressure is achieved.

Control deviation: $\leq 10\%$

Optional with pressure test plugs (It must be selected before delivery)

Application fields



CONDITIONING



HEATING



www.flowsureglobal.com.tr

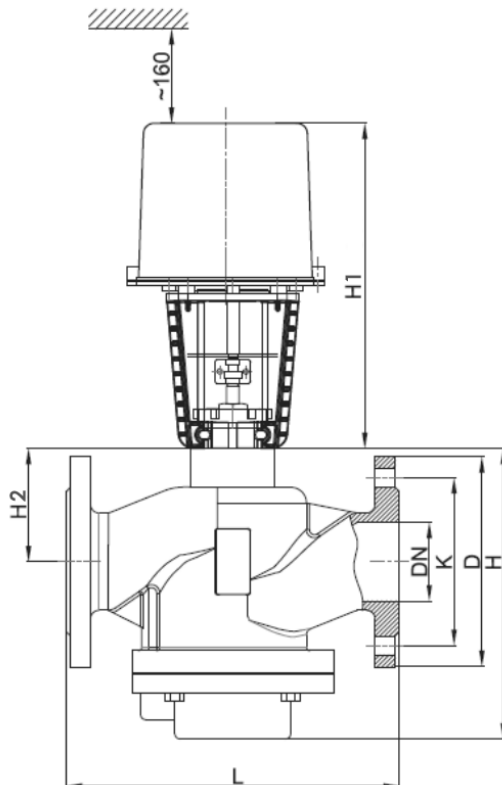

Materials

	Component	Material
1	Body	Nodular cast iron
3	Stem	Stainless steel
4	Trim	Brass, Stainless steel, PPS
5	Spring	Stainless steel
6	Seals	EPDM

Dimensions (mm)

DN	65	80	100	125	150	200	250
L	290	310	350	400	480	495	600
D	185	200	220	250	285	340	405
K	145	160	180	210	240	295	355
H	248	252	296	339	370	448	487
H1	315	315	315	315	315	315	315
H2	90	101	111	127	141	145	210
nxd	4x18	8x18	8x18	8x18	8x22	12x22	12x28

Working Differential Pressure (kPa)

30 - 400							
----------	--	--	--	--	--	--	--

Rated Flow (m³/h)

4 - 24	6.4 - 34	8.4 - 48	19 - 75	20 - 120	28 - 175	32 - 240
--------	----------	----------	---------	----------	----------	----------

Certificates



Standards

Connection standard : EN 1092

Tests : TS EN 12266-1

Nominal Pressure: PN16

Temperature: 1 ~ 110°C

Leakage rate: DIN EN 1349 – Class IV

Scale flow (m³/h)

DN	1.5	2	3	4	5	6	7	8	9	10
65	5.90	6.64	9.02	11.40	13.80	17.22	18.99	20.38	23.30	24
80	8.63	9.45	11.47	14.54	17.83	19.56	25.61	27.11	28.88	32
100	13.00	14.50	19.20	24.00	26.30	31.70	36.80	40.30	44.11	48
125	20.30	22.50	24.80	32.20	38.00	49.50	54.40	63.00	68.60	75
150	20.40	24.10	31.30	40.60	50.00	62.30	74.10	90.40	108	120
200	29.70	35.50	52.80	69.50	85.80	105	120	139.2	153.2	175
250	32	36	42	59	78	101	131	179	216	240

Accessories

- Actuator

FLOW CHARACTERISTICS:

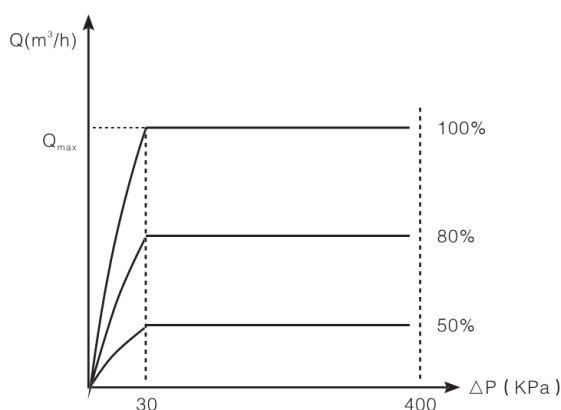

Different Pressure–Flow Characteristics

STORING

- Keep the valve in a dry place, protect from damage and dirt.
- Handle with care, avoid hitting, avoid knocks, especially on the weaker parts.
- Do not lift the valve by the actuator.
- Use suitable, sturdy packing for transport.

RECOMMENDATIONS

Before carrying out maintenance or dismantling the valve: ensure that the pipes, valves and fluids have cooled down, that the pressure has decreased and that the lines and pipes have been drained in case of toxic, corrosive, inflammable and caustic liquids. Temperatures above 50°C and below 0°C might cause damage to people.

Commissioning, decommissioning and maintenance interventions must be carried out by trained staff, taking account of the instructions and local safety regulations.

ADVICE FOR PLANT LAYOUT

- In order to ensure that temperature and pressure limits are not exceeded, the system should be fitted with a thermostat and pressure switches.
- Observe the following minimum distances between the valve and other system components. When connecting to a bend or pump, it is necessary to maintain a certain length of straight pipe. When connecting with elbow, follow valve 5DN, rear 2DN principle; follow the 10DN principle when connecting with a pump.

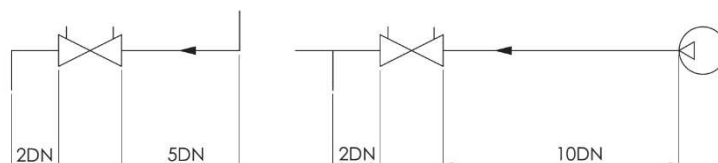

ABOUT CAVITATION

The flow must be free of cavitation.

As the liquid flows through the valve, as a result of section reduction, its velocity and its dynamic pressure increase, and the corresponding static pressure decreases. If the static pressure value drops below the vapour pressure level, steam bubbles will form. These bubbles will be carried away by the fluid, and implode when the static pressure exceeds the vapour pressure again. Bubble implosion generates high temperatures and pressure shock waves locally, which will damage the valve and cause vibrations and noise. Higher temperatures, lower static pressure and higher pressure drops across the valve usually increase the risk of cavitation

INSTALLATION

- Do not lift the valve by the actuator.
- Handle with care
- Before installing, check that:
 - the piping is clean,
 - the valve is clean and undamaged,
 - the flange sealing surfaces are clean and undamaged.
- Use suitable gaskets and check they are correctly centred.
- Do not weld the flanges to the piping after installation of the valve.
- Water hammers might cause damage and ruptures. Avoid inclination, twisting and misalignments of the piping which may subject the installed valve to excessive stresses. It is recommended that elastic joints be used in order to reduce such effects as much as possible.
- Tighten the bolts crosswise
- Do not use with fluids which are petroleum based or containing mineral oil, hydrocarbons, or solvents. Do not use with abrasive fluids.
- Suitable for antifreeze solutions (with minimum 50% water dilution diethylene glycol, ethylene glycol, and propylene glycol).
- Use piping of the same nominal size of the valve.
- The valve must be installed with flow direction same as the arrow on the valve body.
- The balancing valve could be installed in both the water supply pipe and water return pipe. Only one balancing valve is needed in one loop. It is best to install in the water return pipe which temperature is lower.
- The balancing valve in main pipe should be installed in the exit direction of water pump.
- The balancing valve could be installed both horizontally and vertically.
- For trouble-free operation of the product, good installation practice must include initial system flushing (balancing valve must be fully open) and the use of side stream filter(s). Assure there are no solid matters in system.

COMMISSIONING

- Electronic preset of maximum flow facilitates on-site commissioning.
- It is advisable to flush the system clean. Keep the valve fully open when flushing.

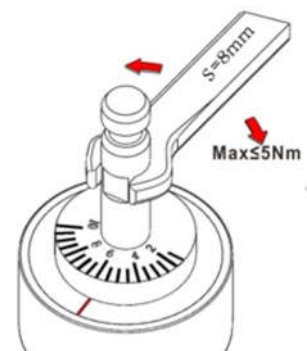

DISPOSAL

For valve operating with hazardous media (toxic, corrosive...) , if there is a possibility of residue remaining in the valve, take due safety precaution and carry out required cleaning operation. Personnel in charge must be trained and equipped with appropriate protection devices.

Prior to disposal, disassemble the valve and separate the component according to various materials. Please refer to product literature for more information. Forward sorted material to recycling (e.g. metallic materials) or disposal, according to local and currently valid legislation and under consideration of the environment.

Actuator



DN65-DN200



DN250

Specification

Enclosure	IP54
Power	Single phase 24V AC (Option: 220V AC)
Motor	AC synchronous motor
Force	1800 – 3000 N
Speed	3.1 s/mm
Maximum Stroke	25mm (1800N) – 50mm (3000N)
Function	Proportional type (Option: 3-point type)
Control signal (for proportional type)	0(2)-10VDC / 0(4)-20mA
Feedback signal (for proportional type)	0(2)-10VDC / 0(4)-20mA

INSTALLATION

- The actuator must not be installed under the valve body.

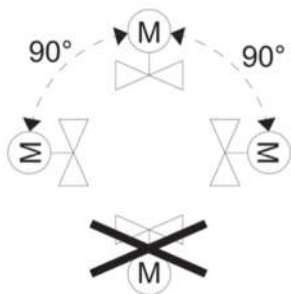

3-point type
Wiring diagram

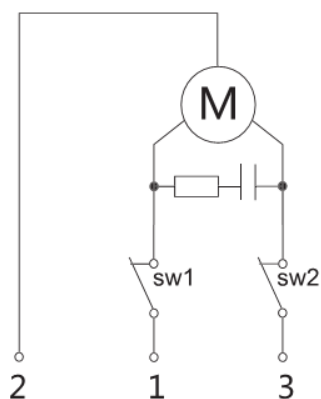

Power Supply Terminals	Direction of Rotation
1-2	↻
2-3	↻

Proportional type
Wiring diagram

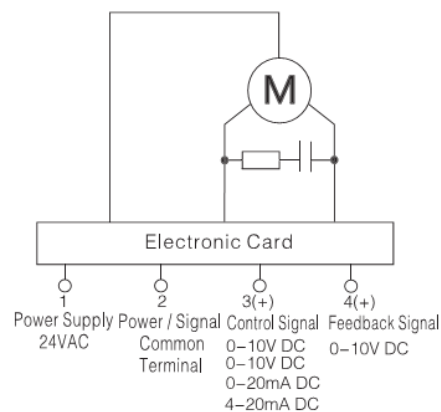

Input Control Signal		Direction of Rotation
DA	RA	
Increase	Decrease	↻
Decrease	Increase	↻