

Serie F.1300



WET ALARM VALVE

F.1300



The wet alarm valve F.1300 is designed for applications where the water is unlikely to freeze. The water staying pressurized in the pipes is released over the fire area after the sprinkler is activated due to fire. The pressurized water system is not only fed continuously, but also fills in the retard chamber. After the chamber is filled, the pressure switch on the chamber is actuated. The pressure switch sends the alarm information to the fire warning system or the automation system. After the pressure switch is actuated, the water is delivered to the water-motor gong and releases a mechanical alarm.

YES: for fire fighting system

Application fields



INDUSTRY



FIRE FIGHTING



www.flowsureglobal.com.tr

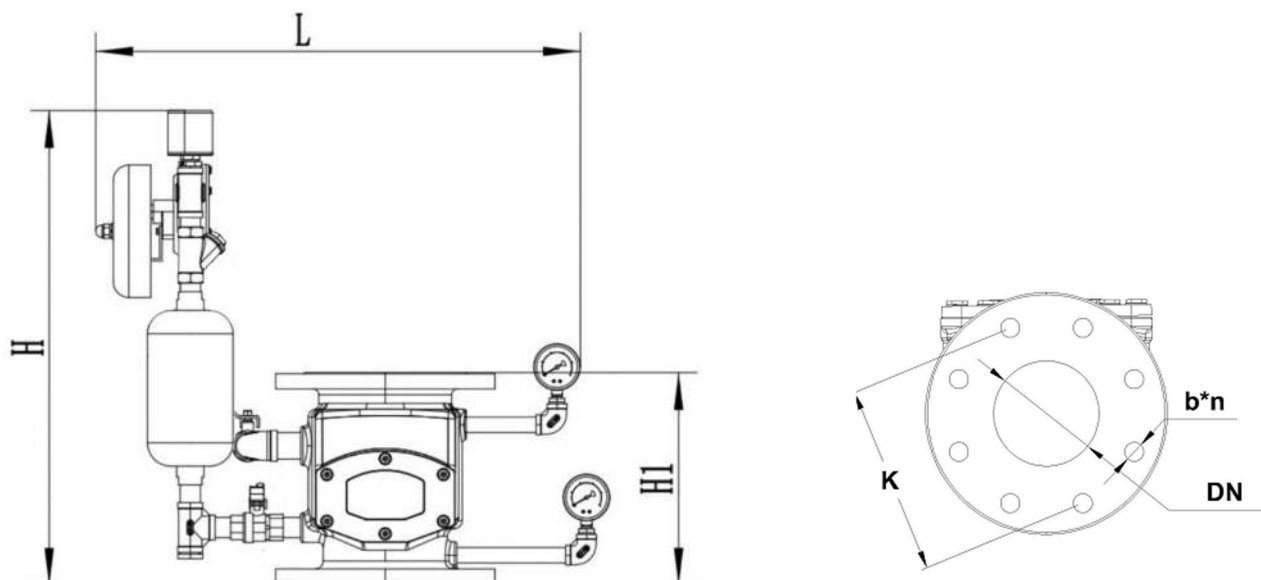

Materials

	Component	Material
1	Body	Ductile iron
2	Bonnet	Ductile iron
3	Clapper	SS304 Stainless steel + NBR Rubber faced
4	Pipe	Galvanized steel
5	Ball valve	Brass
6	Y Strainer	Brass
7	Testing pipe	Copper
8	Retard Chamber	Carbon steel
9	Water Motor Gong	Carbon steel – Aluminium Alloy

Dimensions (mm)

DN		80	100	125	150	200	250
H		605	605	615	615	615	625
H1		240	240	273	273	296	318
L		625	625	655	655	700	755
W		350	350	400	400	445	495
EN1092-2 PN16	K	160	180	210	240	295	355
	b*n	18 x 8	18 x 8	18 x 8	22 x 8	22 x 12	26 x 12
ANSI #150	K	152.5	190.5	216	241.5	298.5	362
	b*n	19 x 4	19 x 8	23 x 8	23 x 8	23 x 8	25 x 12

Certificates



Standards

Design : TS EN 5153
 Flange Dimensions : EN 1092-2 / ANSI
 Face to Face Dimensions : TS EN 5153
 Tests : TS EN 12266-1
 Nominal Pressure: PN16
 Temperature: +4 ~ 70°C

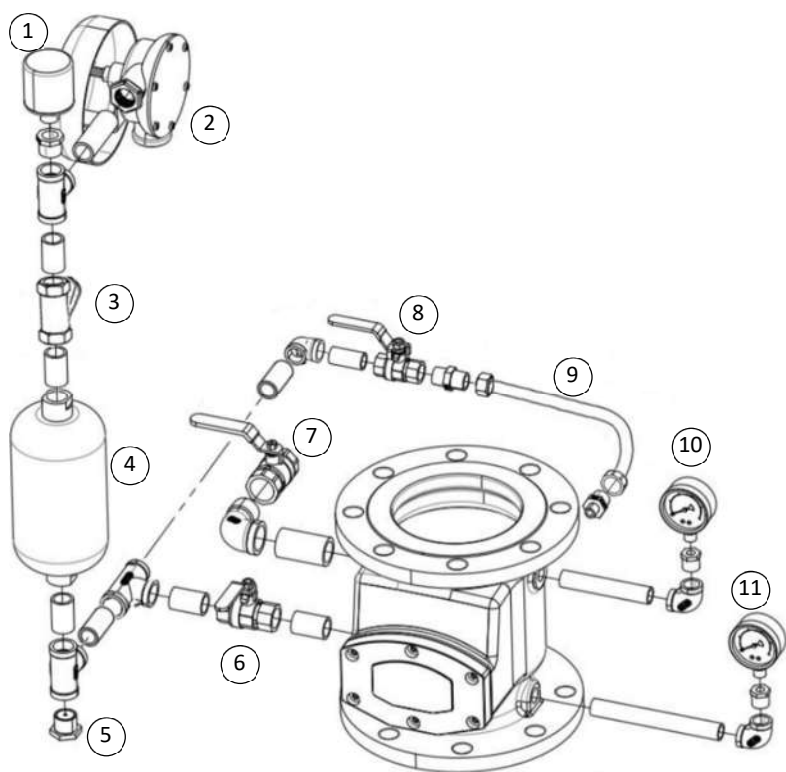

	Component
1	Pressure Switch
2	Water Motor Alarm Gong
3	Y Strainer
4	Retard Chamber
5	Restriction Assembly 3.2mm Orifice Outlet
6	Alarm Shut-off Valve (normally opened)
7	Main Drain Valve (normally closed)
8	Alarm Testing Valve (normally closed)
9	Copper Pipe
10	System Pressure Gauge
11	Supply Pressure Gauge

Specification

Installation	Vertical
Retard chamber Capacity	4 Litres
Retard chamber time delay	$5 < t < 90$ seconds
Water motor Gong Operating pressure	< 0.035 bar
Water motor Gong loudness	> 90 dB @ 14 bar
Pressure switch Operating pressure	$0.035 \sim 0.5$ bar
Pressure switch Contact rating	10A@230VAC or 2A@24VDC

Instruction and Recommendations

STORING

Keep in dry and closed place.

GENERAL DESCRIPTION

The model F.1300 Wet Alarm Valves (DN100 to DN200) are used in wet pipe fire sprinkler systems. They primarily serve a dual purpose in that they prevent a reverse flow of water through their bodies (non-return) and also provide for the use of a hydraulic fire alarm which is not dependent upon an electrical power supply for its operation.

Through the use of a hydraulic retard chamber a time delay is provided to eliminate potential false alarms caused by fluctuating water supply pressures. Where constant pressure water supplies are used the retard chamber (time delay) is not necessary. By incorporating the use of electrical pressure switches, other supplemental alarms, annunciators, etc. may also be used.

RECOMMENDATIONS

It is most important to ensure a clean water supply free of debris and solid particles such as sand, gravel, or mud.

If, during the annual inspection of alarm check valves, sediment or free particles of matter are noted, a further examination of internal valve parts becomes necessary.

All deposits should be removed from all operating parts and ports. Vent holes through seat ring, should be thoroughly cleaned and flushed with clean water.

Where difficulty in performance is experienced, the manufacturer or his authorized representative shall be contacted if any field adjustment is to be made

OPERATING PRINCIPLES

When the fire protection system is initially being pressurized, water will flow into the system until the water supply and system pressure become equalized, and the Spring closes the Clapper in the Alarm Valve.

Once the pressures have stabilized, the Alarm Valve is in service and the centrally located groove in the Seat Ring is sealed. Consequently, with the Alarm Check Valve set for service, there is no flow through the alarm port to the alarm devices (that is, water motor alarm and/or pressure alarm switch).

When there is a steady flow of water into the sprinkler system due to a sprinkler operation, the Clapper opens. Water is then permitted to flow into the centrally located groove in the Seat Ring and out through the alarm port towards the Drain Valve. When the flow from the alarm port exceeds the drain capacity of the Drain Valve, the Retard Chamber (where provided in the case of systems with variable pressure) begins to fill as a function of the amount of water that can pass through the Restriction. Subsequently, the water motor alarm and/or the pressure alarm switch will be actuated. The alarms will continue to actuate as long as the Clapper remains opened. Water in the alarm lines will automatically drain out through the Drain Valve when the Clapper closes (due to discontinuation in the flow of water into the sprinkler system).

In the case of variable pressure systems, slow as well as small transient increases in water supply pressure may continue to build up in the system (via the bypass check valve) without opening the Clapper. A transient surge in supply pressure which is sufficient to only momentarily open the Clapper will not cause a false alarm, and a portion of the increase in pressure will be trapped within the system, thus reducing the possibility of another opening. Any water in the alarm line is automatically drained, further reducing the possibility of a false alarm due to a successive transient surge in supply pressure.

INSTALLATION

- Proper operation of the F.1300 Wet Alarm Valves depends upon its trim being installed. Failure to follow the appropriate trim diagram may prevent the valve from functioning, may void the Manufacturer's Warranty.

- The Alarm Valves must be installed in readily visible and accessible locations.

- It is recommended that provision be made for viewing the alarm line drain water by locating the drain outlet in a readily visible area.

- The F.1300 Wet Alarm Valves must be installed in an area not subject to freezing temperatures or physical damage. It must be maintained at a minimum temperature of 4°C to 70°C.

- The F.1300 Wet Alarm Valves must be installed in the vertical position with direction of flow up.

1. Verify that auxiliary drains are closed and that the system is free of leaks.
2. Open the system test valve (and any auxiliary vents provided to facilitate removal of air from the system) to allow air to escape from the system while it is filling with water.
3. If desired, close the alarm shut-off valve to prevent local alarms from operating while filling the system.
4. Slowly open the water supply main control valve.
5. Allow the system to completely fill with water. Allow water to flow from the system test valve, and any other open vents provided, until all air is exhausted from the system.
6. After all air is exhausted from the system, close the system test valve and all other open vents.
7. The System Pressure Gauge on the system side of the Wet Alarm Valves Clapper should indicate water pressure equal to or greater than the Supply pressure indicated on the gauge located on the supply side of the clapper.
8. OPEN the Alarm Shut-Off Valve in the Alarm Valve trim, and verify that all other valves are in their normal operating position.
9. Secure all valves in their normal operating position.

10. Notify the Authority Having Jurisdiction, remote station alarm monitors, and those in the affected area that the system is in service.

TESTING

Testing Alarm Valve and Water flow Alarm Devices

NFPA 25 recommends that the alarm valve and its water flow alarm devices be tested at least quarterly. The primary way to test this equipment is by opening the System Test Valve. This System Test Valve, generally located at the highest and most remote point on the system in relation to the alarm valve. Opening System Test Valve, and the subsequent discharge of water through the System Test Valve, simulates the operation of a sprinkler. Therefore, alarm devices should sound and/or operate when the System Test Valve is opened.

An alternate means of testing water flow alarm devices is to open the Alarm Test Valve provided as part of the alarm valve trim. It must be noted, however, that opening of this valve only tests the alarms; it does not test the operation of the alarm valve since the supply for the alarm test line is taken from a point below the alarm valve clapper. This means of testing, therefore, should only be used when weather conditions or other circumstances prohibit using the System Test Valve.

Note: If alarms connect to a central station or fire department, notify the signal receiving station when all tests have been completed.

Flow Test at Main Drain Valve (Main Drain Test)

NFPA 25 recommends that a water flow test be made quarterly from the main drain valve at the system riser. The purpose of this test is to show whether or not the normal water supply is available to the system. By comparing static and residual pressure readings with those previously established, a main drain test can indicate the possible presence of closed valves or other obstructions in the supply piping. The procedure for conducting a Main Drain Test is as follows:

1. With the Main Drain Valve closed, note and record the reading on the Supply Pressure Gauge at the Alarm Valve.
2. Open the Main Drain Valve slowly until it is wide open. Then, check to make sure that a full steady flow of water is discharging from the main drain pipe.

Note: If a full steady stream is not discharging, check the main drain piping further for possible obstructions.

3. Allow the water to flow until the reading on the Supply Pressure Gauge drops and stabilizes. Then, record this reading.

Note: The first and higher pressure reading is the static pressure. The second, lower reading is the residual pressure with a given flow discharging from the main drain pipe.

4. Close the Main Drain Valve slowly.

Caution: If alarms have been temporarily shut off, they must be returned to service. If alarms connect to a central station or fire department, notify the signal receiving station when the test has been completed.

5. Compare both pressure readings with previously established or normal readings.

Note: If the readings compare favorably, the water supply may be considered satisfactory. If, however, the pressure readings vary to any great extent, the condition should be investigated to determine the cause. Some possible causes are:

Partially or totally closed system control valves.

Clogged or frozen water mains.

Serious leakage at valves or mains

MAINTENANCE

The F.1300 Wet Alarm Valves and its related equipment should be examined periodically to ensure proper operation and trouble-free service.

- Verify that if the Water Supply Control Valve is completely opened.
- Ensure the reading of System Pressure Gauge and Supply Pressure Gauge is same as the designed pressure when the system is installed.
- Test the Wet Alarm Valves as the above testing steps quarterly.
- Disassembled and clean the Alarm Check Valve yearly.