

Serie F.600



BRASS DYNAMIC BALANCING VALVE WITH ACTUATOR

F.620



The valves F.620 balance the flow in main circuits or single sections of heating or conditioning plants.

They allow correcting irregularities in the supply of the single users (irregularities which might cause noise and damage the components of the plant) and, as a result, improve environmental comfort and optimize energy consumption.

They perform shut-off and measuring functions. Flow value is not influenced by pressure undulation and is not influenced by each other.

They can be installed indifferently on the supply piping and on the return piping.

It saves more 6-20% energy than traditional system

Application fields



CONDITIONING



HEATING



www.flowsureglobal.com.tr

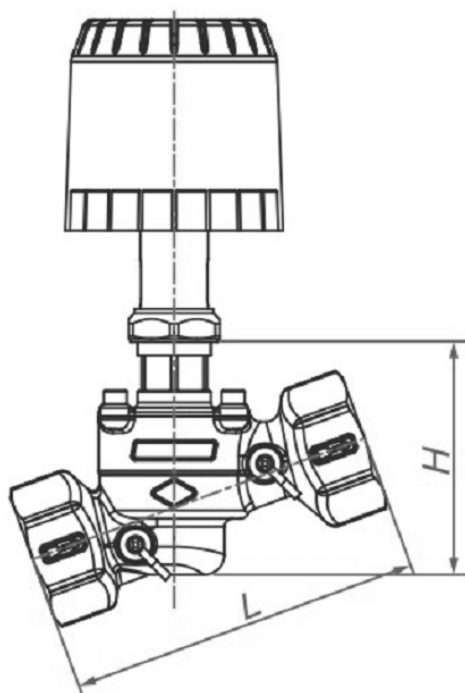

Materials

	Component	Material
1	Body	C3771 – Brass
2	Core	Brass
3	Stem	06Cr19Ni10 - Stainless steel
4	Seals	PTFE
5	Diaphragm	EPDM

Dimensions (mm)

DN	20	25	32	40	50
L	100	110	130	150	170
H	135	144	145	150	170

Maximum Differential Pressure

	150	70	300	300	300
--	-----	----	-----	-----	-----

Kvs

	0.9	1.5	3.5	6	8
--	-----	-----	-----	---	---

Certificates



Standards

Thread standard : ISO 7-1
 Tests : TS EN 12266-1
 Nominal Pressure: PN25
 Temperature: -10 ~ 120°C

STORING

- Keep the valve in a dry place, protect from damage and dirt.
- Handle with care, avoid hitting, avoid knocks, especially on the weaker parts (hand wheel).
- Do not lift the valve by the hand wheel.
- Use suitable, sturdy packing for transport.

RECOMMENDATIONS

Before carrying out maintenance or dismantling the valve: ensure that the pipes, valves and fluids have cooled down, that the pressure has decreased and that the lines and pipes have been drained in case of toxic, corrosive, inflammable and caustic liquids. Temperatures above 50°C and below 0°C might cause damage to people.

Commissioning, decommissioning and maintenance interventions must be carried out by trained staff, taking account of the instructions and local safety regulations.

ADVICE FOR PLANT LAYOUT

- In order to ensure that temperature and pressure limits are not exceeded, the system should be fitted with a thermostat and pressure switches.
- Observe the following minimum distances between the valve and other system components. When connecting to a bend or pump, it is necessary to maintain a certain length of straight pipe. When connecting with elbow, follow valve 5DN, rear 2DN principle; follow the 10DN principle when connecting with a pump.

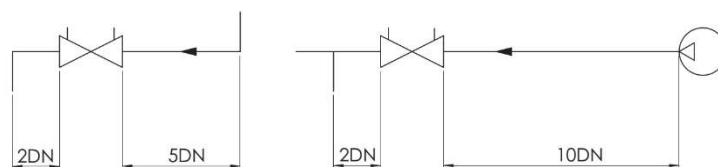
**ABOUT CAVITATION**

The flow must be free of cavitation.

As the liquid flows through the valve, as a result of section reduction, its velocity and its dynamic pressure increase, and the corresponding static pressure decreases. If the static pressure value drops below the vapour pressure level, steam bubbles will form. These bubbles will be carried away by the fluid, and implode when the static pressure exceeds the vapour pressure again. Bubble implosion generates high temperatures and pressure shock waves locally, which will damage the valve and cause vibrations and noise. Higher temperatures, lower static pressure and higher pressure drops across the valve usually increase the risk of cavitation

INSTALLATION

- Do not lift the valve by the hand wheel.
- Handle with care
- Before installing, check that:
 - the piping is clean,
 - the valve is clean and undamaged,
 - the flange sealing surfaces are clean and undamaged.
- The valve is unidirectional; respect the flow direction indicated by the arrow on the body.
- Use suitable gaskets and check they are correctly centered.
- Do not weld the flanges to the piping after installation of the valve.
- Water hammers might cause damage and ruptures. Avoid inclination, twisting and misalignments of the piping which may subject the installed valve to excessive stresses. It is recommended that elastic joints be used in order to reduce such effects as much as possible.

COMMISSIONING

- It is advisable to flush the system clean. Keep the valve fully open when flushing.
- If a system pressure test is required, the maximum allowed pressure PS may be exceeded by up to a maximum of 37.5 bar. Pressure tests must be carried out at room temperature and with the valve fully open.

DISPOSAL

For valve operating with hazardous media (toxic, corrosive...) , if there is a possibility of residue remaining in the valve, take due safety precaution and carry out required cleaning operation. Personnel in charge must be trained and equipped with appropriate protection devices.

Prior to disposal, disassemble the valve and separate the component according to various materials. Please refer to product literature for more information. Forward sorted material to recycling (e.g. metallic materials) or disposal, according to local and currently valid legislation and under consideration of the environment.