

Serie F.800



PRESSURE REDUCING VALVE

F.800



The flanged pressure reducing valves, globe type, are suitable for reducing and controlling the pressure.

They are made of ductile iron, with an epoxy coating. The valves are suitable for water supply, fire fighting, industrial systems and agricultural irrigation.

YES: the pressure reducing valve is used to:

- Supply a low pressure network from a high pressure network.
- Protect a delicate section of a plant or device
- In sanitary networks, to keep the pressure level under a maximum value.
- Downstream of tanks or accumulation basins, to reduce and stabilize the pressure of the distribution network.

NO: for steam and gas.

Application fields



WATER



INDUSTRY



DRINKING WATER



FIRE FIGHTING



www.flowsureglobal.com.tr

Materials

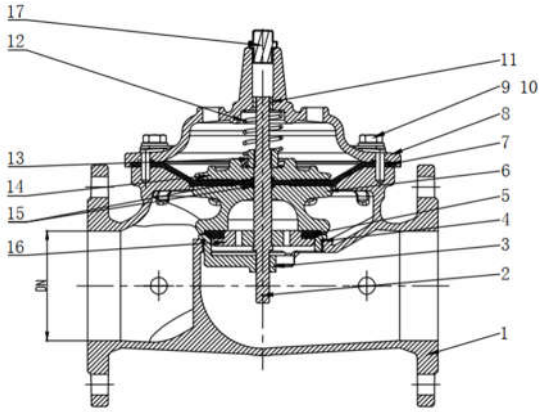

	Component	Material
1	Body	Ductile Iron
2	Stem	AISI304 – Stainless Steel
3	Seat	AISI304 – Stainless Steel
4	O Ring	NBR
5	Sealing Gasket	NBR
6	Mounting Plate	Ductile Iron
7	Diaphragm	NBR
8	Bonnet	Ductile Iron
9	Bolt	AISI304 – Stainless Steel
10	Plain Washer	AISI304 – Stainless Steel
11	Guide Bush	CuZn39Pb1 Brass
12	Spring	AISI304 – Stainless Steel
13	Check Nut	AISI304 – Stainless Steel
14	Top Board	Ductile Iron
15	O Ring	NBR
16	Lower Platen	AISI304 – Stainless Steel
17	Plug	AISI304 – Stainless Steel

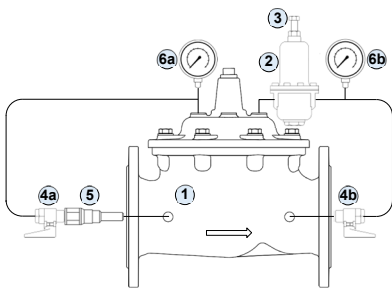

Materials

	Component	Material
1	Body	Ductile Iron
2	Pilot valve	Stainless Steel
3	Adjust Screw	Steel
4	Ball Valve	Brass
5	Strainer	Brass
6	Pressure Gauge	Stainless steel case

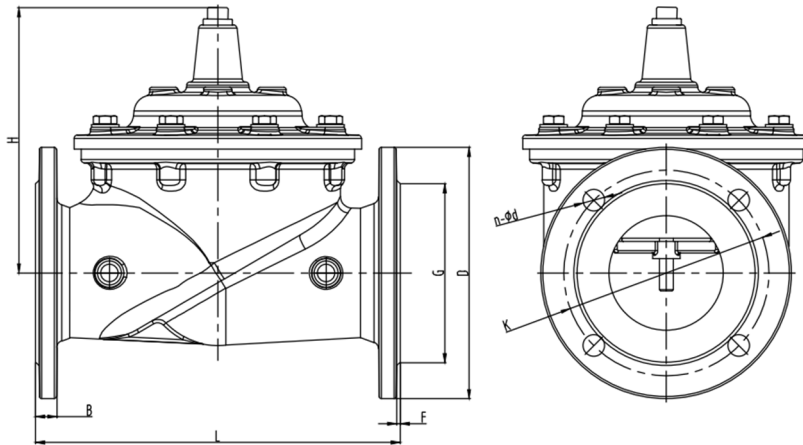

Dimensions (mm)

DN	50	65	80	100	125	150	200	250	300	350	400	500	600
L	230	290	310	350	350	480	600	730	850	980	1100	1250	1450
D	165	185	200	220	250	285	340	405	460	520	580	715	840
K	125	145	160	180	210	240	295	355	410	470	525	650	770
G	99	118	132	156	184	211	266	319	370	429	480	609	720
n-d	4-Ø19	4-Ø19	8-Ø19	8-Ø19	8-Ø19	8-Ø23	12-Ø23	12-Ø28	12-Ø28	16-Ø28	16-Ø31	20-Ø34	20-Ø37
B	19	19	19	19	19	19	20	22	24.5	27	28	32	36
F	3	3	3	3	3	3	3	3	4	4	4	4	4
H	150	175	215	220	220	335	415	500	550	550	650	743	870

Certificates



Standards

Flange Dimensions : TS EN1092-2 (PN 16)

Face to Face Dimensions : TS EN 558-1

Tests : TS EN 12266-1

Nominal Pressure: PN16 (Option: PN25)

Temperature: 0 ~ 70°C

Head Loss

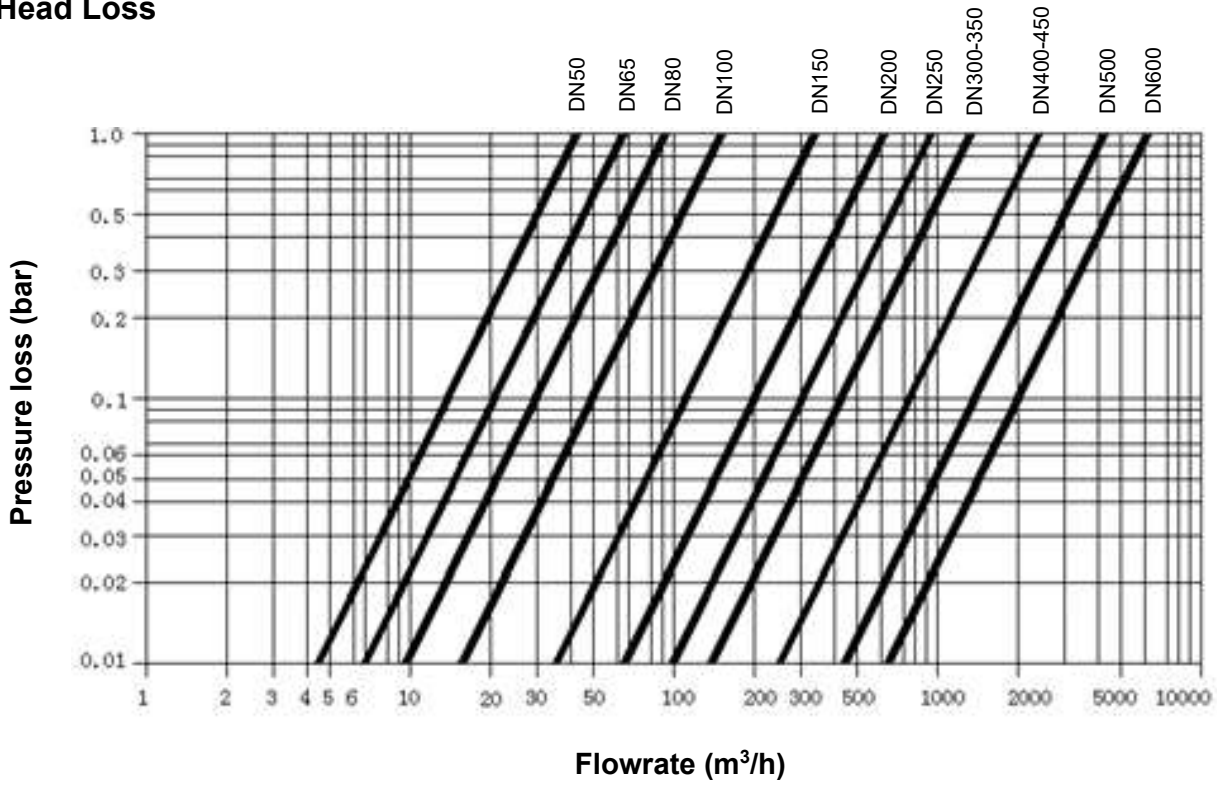

Cavitation Diagram

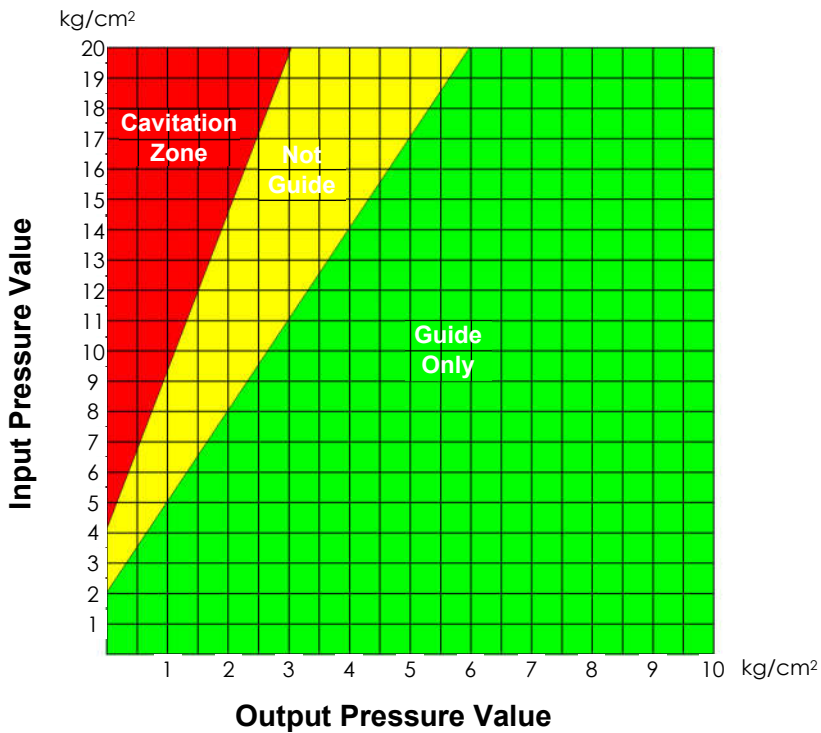

*High differential pressures across the PRV will result in noisy operation and could result in premature failure of the PRV due to internal cavitation

Instruction and Recommendations

STORING

- Keep in dry and closed place.

RECOMMENDATIONS

Before carrying out maintenance or dismantling the valve:

- Ensure that the pipes, valves and fluids have cooled down
- That the pressure has decreased, and that the lines and pipes have been drained in case of toxic, corrosive, inflammable or caustic liquids.

Temperatures above 50°C and below 0°C might cause damage to people.

INSTALLATION

- Handle with care
- Install the pressure reducing valves in a horizontal position, for the best working situation, in order to reduce wear of the internal part; if necessary, it is possible to install the pressure reducing valve in a vertical position.
- Before installing the valve, ensure that the piping is cleaned thoroughly in order to avoid damage to the internal parts of the valve caused by residues and stones.
- Place the valve between the flanges of the pipe and install the seal between the pipe and valve flanges. Check that the seals are positioned correctly.
- The distance between the counterflanges must be equal to the valve's face to face distance.
- Do not use the bolts of the counterflanges to bring the piping close to them. The bolts must be cross tightened.
- Do not weld the flanges to the piping after installing the valve.
- Water hammers might cause damage and ruptures. Inclination, twisting and misalignments of the piping may subject the installed valve to excessive stresses. It is recommended that elastic joints be used, in order to reduce such effects as much as possible.
- These valves are unidirectional: install in accordance with the flow direction arrow indicated on the body.
- Valve can be assembled horizontally or vertically.
- In order to prevent the cavitation, It is advisable to reduce the downstream pressure to 1/3 of the maximum upstream pressure in main line and with high upstream pressure, 2 valves should be assembled to reduce the pressure gradually and safely.

INDICATIONS TO BE MADE WHEN ORDERING:

- Maximum flowrate
- Upstream pressure value (min and max)
- Downstream pressure value

ADJUSTMENT

- Step 1: Get the water in the line
- Step 2: Close the small ball valve (4b) on the outlet side on main valve
- Step 3: When the adjusting bolt (3) on the pilot (2) is released completely, the pressure on the downstream pressure gauge (6b) is zero value.
- Step 4: Rotate adjusting bolt (3) clockwise, adjusting pressure rises and continue until getting the desired downstream pressure value.
- Step 5: When you receive the demanded pressure value, the small ball valve (4b) will be opened fully, and you maintain regular downstream pressure in the system.